

# SEPARSAND SS

## ALIMENTATION

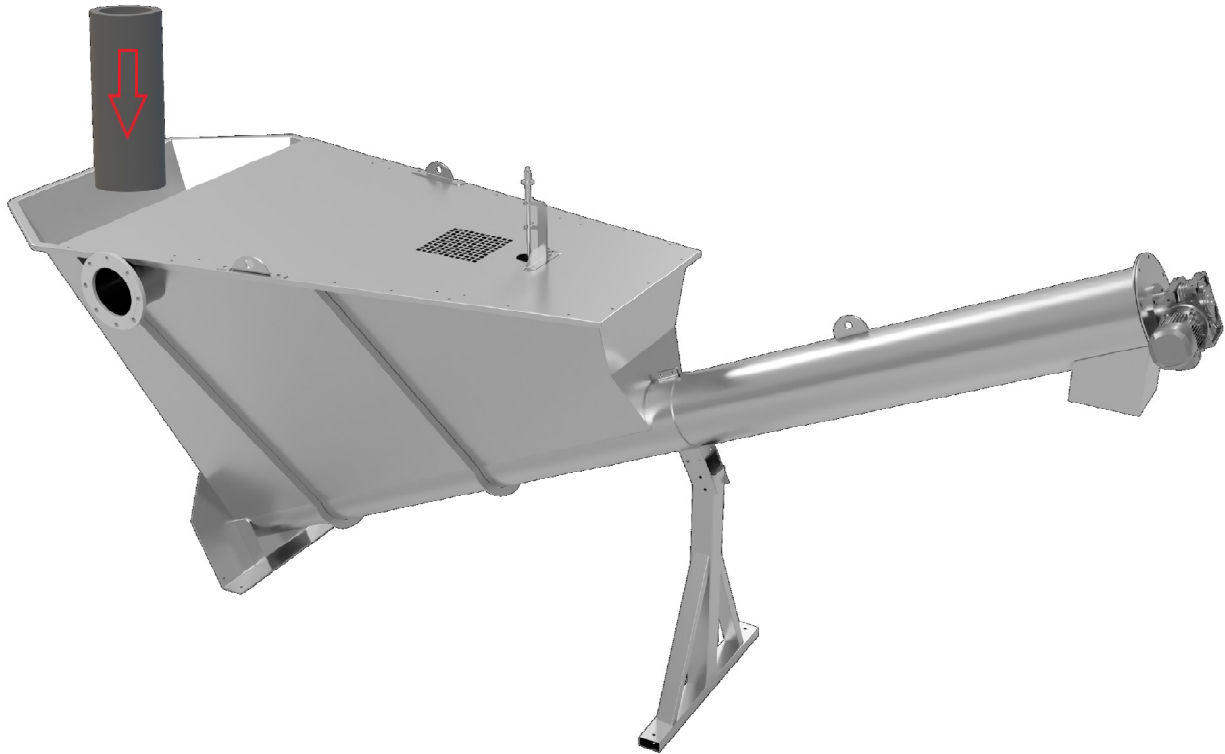

SEPARSAND (Modello)	PORTATA (l/min)
SS 600	600
SS 1000	1000
SS 1400	1400
SS 2000	2000

**1. PROVENIENZA DELL'ACQUA DA TRATTARE**

**2. PORTATA DA TRATTARE m<sup>3</sup>/h**

**3. FLUSSO CONTINUO O DISCONTINUO**